

Contained in this document is a variety of proposed marker and project designs. Please let us know if there is anything here that you would like to change or have additional information on.

Below is the overall design plan for the pinecone cutouts.

Pinecone Cutouts: Modified Asymmetric

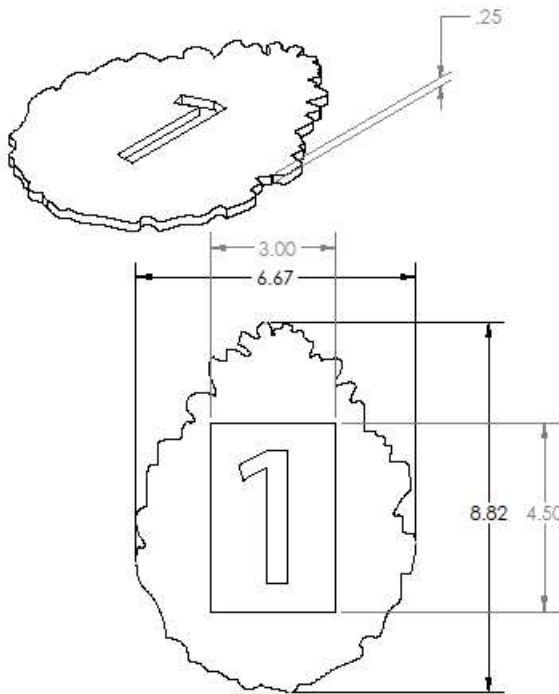

Mechanical:

- All cutouts from 1/4" hot rolled pickled and oiled steel
 - Cutouts made via CNC cutting machine
 - Pinecone cutout is approximately 6.1in x 8.57in in size
 - All pinecones have a 3in x 4.5in backing plate
 - Numbers with holes on them are also cut out:
 - Weld "hole" onto backing plate after determining correct position
 - Grind down welds as necessary to fit the pinecone
 - Weld pinecone onto backing plate as positioned correctly
- Alternately, these numbers can be remade with bridges to the holes, allowing for them to simply be part of the CNC cut and then welded onto the backing plate for stability.

Assuming cuts are given a 1/2" leeway, with 6.5x9in used for pinecones and 3x4.5in for backing plates:

- Assuming perfect welds and cuts, with no error: 2' x 4' sheet
- Assuming 20% waste: 2' x 5' or 3' x 4'

*See other document for layout.

Technical:

- Adobe Helti Std used for numbers
- Convert pinecone top face to .dwg for CNC machine
- All measurements in inches unless specified otherwise

SOLIDWORKS Educational Product. For Instructional Use Only.

Davis Creek Trail Marker Restoration Project
November 23, 2019

Below are the modified pinecone cutout designs.

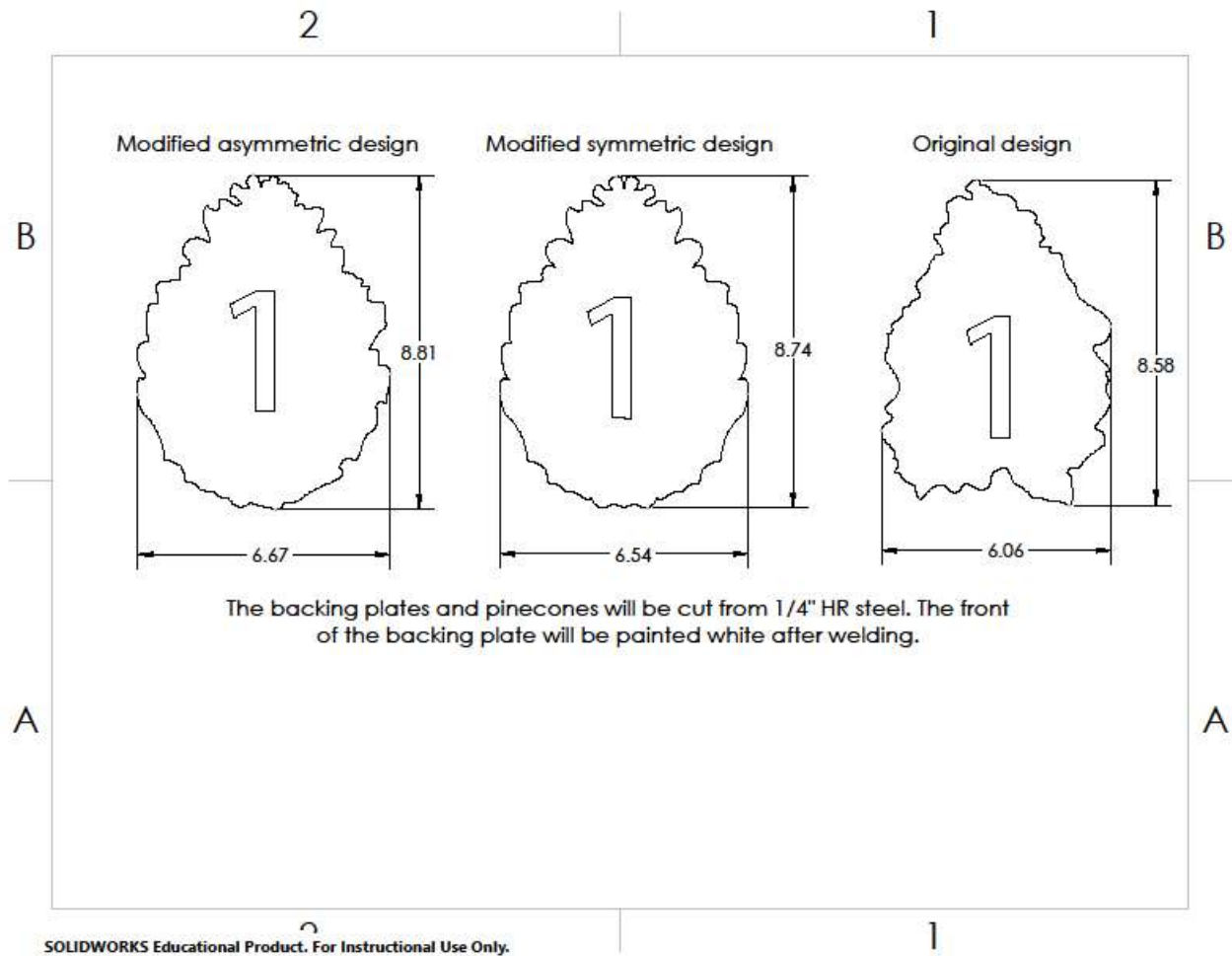

The original design was made very close to the cutouts that are currently at the Nature Trail; however, their irregular shape can make it difficult to properly cut and position both the number and the backing plate.

Thus, we opted to make a new design that is more manageable by the CNC machine and has a more regular shape, which we believe will make positioning the number cutout and backing plate more straightforward (while still looking somewhat like a pinecone).

All designs still use 1/4" HR steel for the backing plate and pinecone.

All dimensions are in inches.

Davis Creek Trail Marker Restoration Project
November 23, 2019

Below is the design plan for the overall marker. It has closely followed the model present on the original proposal but provides additional detail for other purposes.

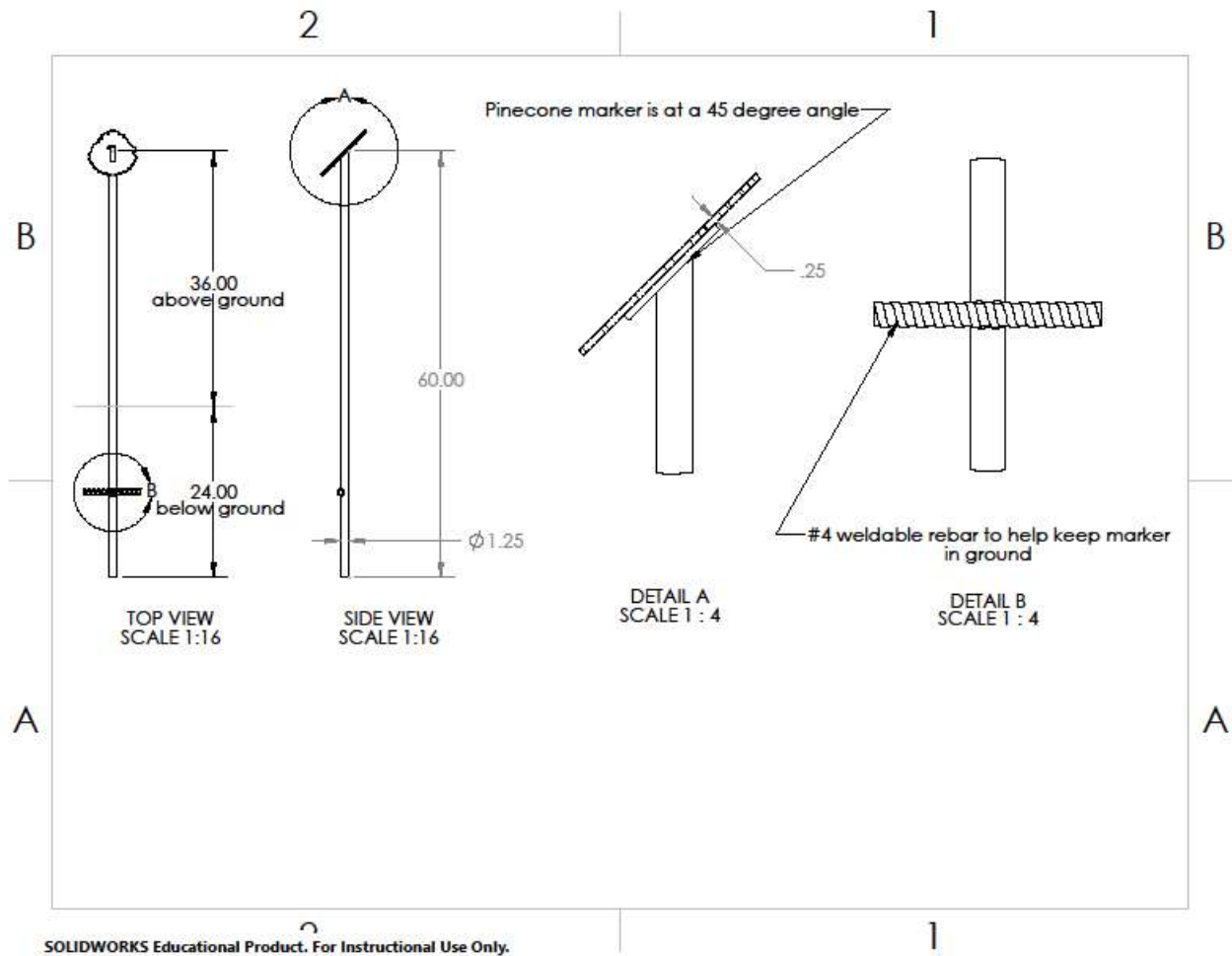

The markers currently installed on the Nature Trail were measured to be at a 40 degree angle from the ground; however, we intend to cut the pipes to be at a 45 degree angle instead (with minimal material loss). We can provide 3D-printed scaled-down models of the pinecones at various angles when our printers are available, if you would like.

#4 (0.5 in diameter) ASTM A706 weldable rebar will be used to keep the marker in the ground. If necessary, additional rebar can be welded on, but may take some additional time.

Davis Creek Trail Marker Restoration Project
November 23, 2019

Possible Metal Sheet Layout (1/4" thickness, HRPO)

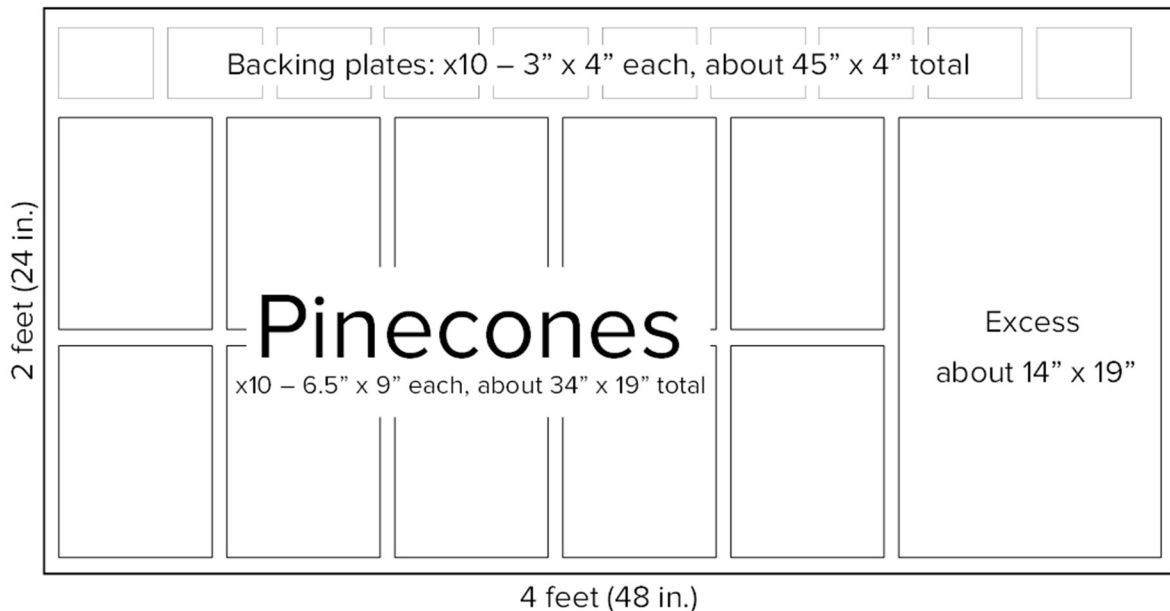

Conservative estimate; we are likely to have a significant amount of excess material to account for errors.

Above is the sheet metal layout that we expect to use. This is a best-case scenario; we expect to have double the metal displayed above (4' x 4', rather than 2' x 4'), which allows us to both add extra space between each object when cutting and improve the design if necessary.

We may use any excess towards resolving issues arising from the CNC machine or creating models for demonstration purposes.



Davis Creek

Trail Marker Restoration Project

Above is a basic project logo/banner that we expect to use with social media accounts or other media distributions both within our school and on online platforms. We are in the process of creating a website with detailed information on the project, including all school documents, images, supporter details, and more. We can provide additional information on our online presence as the project progresses.

The logo is not final and may change over time.